

2014 Gulfstream G650 6085



FREESTREAM.COM
sales@freestream.com

29 Bruton Place London W1J 6NJ, UK
+44 20.7584.3800

Alireza Ittihadieh

2014 Gulfstream G650 6085

AIRCRAFT LISTING DETAILS

Airframe *As of 14th May 2026*

Total Time: 3418

Total Landings: 1622

APU *Honeywell RE220 (GVI)*

Total Time: 3613

Total Cycles: 684

Enrolled on: Honeywell MSP (& Mechanical)

Engines *BR725A1-12*

Total Hours: 3418 3418

Total Cycles: 1622 1622

Enrolled on: RRCC

HIGHLIGHTS

- Fresh 144-month Inspection
- US Registered
- Customized 15 Passenger Layout
- Honeywell L5Z-860 Lighting System
- Starlink Internet
- KA Band Internet
- Part 135 Certified
- Enhanced Soundproofing
- Secureplane 500 System
- 7220 CabinView™
- Passenger Flight Information System
- CGMS controllers 2.0
- 7720 Honeywell SwiftBroadband Data System
- External Colour Camera System
- Forward Galley and Crew Rest
- Honeywell INMARSAT Satellite Communications System



AVIONICS EQUIPMENT/ OPTIONS

- Runaway Awareness Advisory System (RAAS)
- Flight Management System (FMS) VHF
- Communication / Navigation Inertial
- Reference System (IRS) Automated
- Direction Finder (ADF) Enhanced
- Vision System (EVS) Central
- Maintenance Computer (CMC)
- AirTraffic Control (ATC)
- EGPWS
- FANS Head Up Display (HUD)
- SATCOM VHF Navigation
- Part135 Compliant
- Dual GPS
- EVS II
- Block III Baseline with Predictive Weather
- Honeywell LSZ-860 Lighting System
- Triplex Flight Management System



2014 Gulfstream G650 6085

AVIONICS EQUIPMENT/ OPTIONS

- GDC Datalink Service Provider
- Honeywell PlaneView II Satcom System
- Aircell Axxess II Iridium Satellite Telephone System
- One (1) dual slot Blu-ray/DVD/CD player incorporating dual 160GB media servers and
- Two (2) USB ports is installed in the forward left-hand cabinet
- One (1) 17" widescreen HD LCD monitor is installed in the crew rest compartment
- One (1) 26" widescreen HD LCD monitor is installed in the forward right-hand cabin bulkhead
- One (1) 26" widescreen HD LCD monitor is installed in the aft left-hand side of the mid-cabin bulkhead
- Eight (8) 12.1" widescreen HD LCD personal monitors installed in armrest of each single seat in cabin
- Honeywell INMARSAT Satellite Communications System
- 7800 SecuraPlane 500 Aircraft Security System
- Communications (ATA 23) - ARINC – Datalink Service Provider
- Information Systems (ATA 46)
- Aircraft Health Trend Monitoring System (AHTMS)
- Airtto-Ground Link
- Navigation (ATA 34) Predictive Windshear (PWS) – Activation



2014 Gulfstream G650 6085

INTERIOR

Number Of Passengers:	Fifteen (15) Passenger Configuration- Sleeping for Seven (7)
Galley:	Fwd. Refrigerator with Removable Shelves and Freezer
Fwd. Cabin:	Four (4) Place Captain Chairs
Mid Cabin:	Four (4) Place Conference Group Opposite Two (2) Single Seats
Aft. Cabin:	One Three (3) Place Berthable Divan Facing Two (2) Single Seats
Crew Rest:	Fwd. Crew Compartment
Materials:	High Gloss Dark Etimoe Veneer and Luxurious Cashmere and Leather Seats. The Dark Wood Is Topped with Granite Countertops, and the Floors Are Covered In a Silk Blend Carpet For Ultimate Comfort and Luxury.
Misc:	Electrically Operated Console Tables, Electric Window Shades SVS



2014 Gulfstream G650

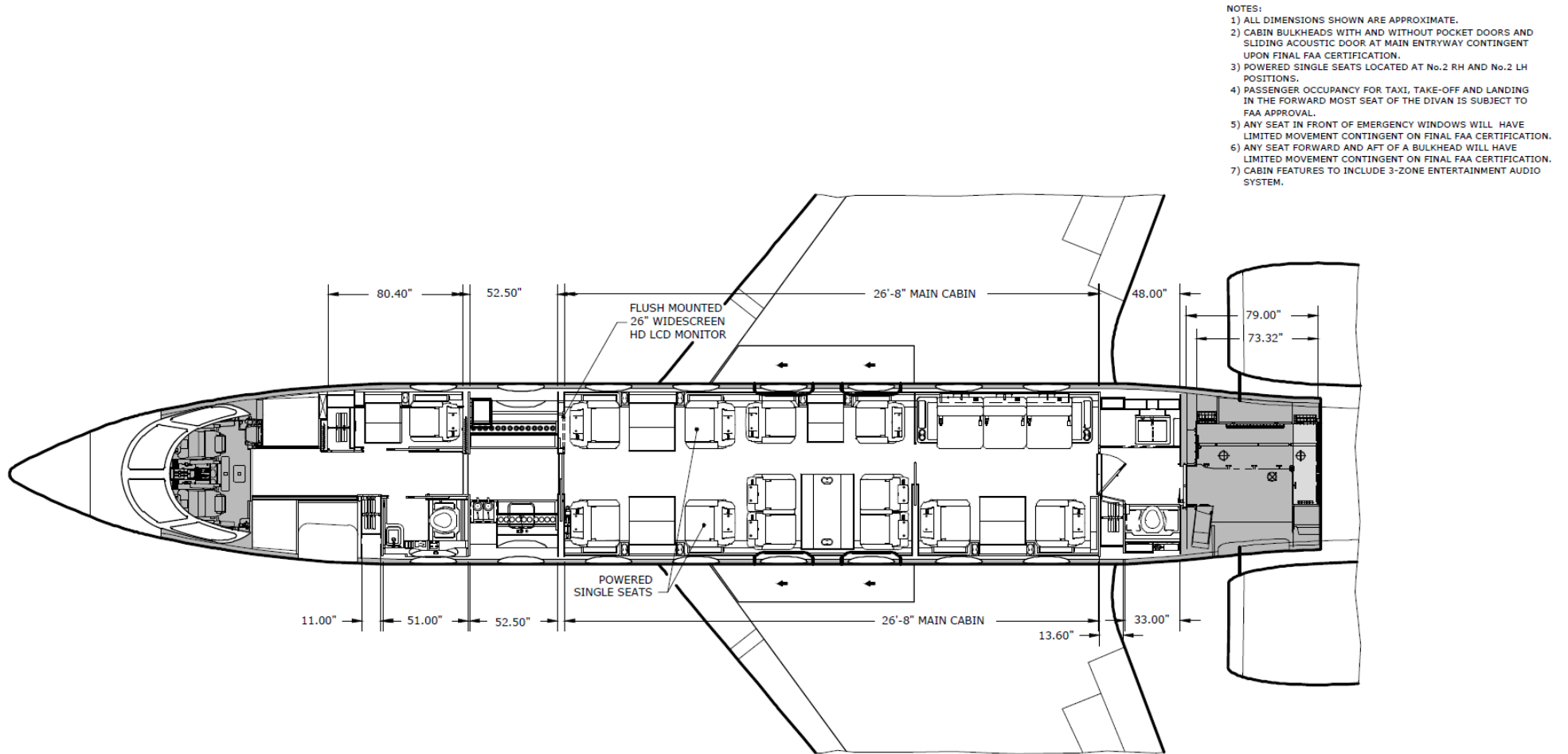

- NOTES:
- 1) ALL DIMENSIONS SHOWN ARE APPROXIMATE.
 - 2) CABIN BULKHEADS WITH AND WITHOUT POCKET DOORS AND SLIDING ACOUSTIC DOOR AT MAIN ENTRYWAY CONTINGENT UPON FINAL FAA CERTIFICATION.
 - 3) POWERED SINGLE SEATS LOCATED AT No.2 RH AND No.2 LH POSITIONS.
 - 4) PASSENGER OCCUPANCY FOR TAXI, TAKE-OFF AND LANDING IN THE FORWARD MOST SEAT OF THE DIVAN IS SUBJECT TO FAA APPROVAL.
 - 5) ANY SEAT IN FRONT OF EMERGENCY WINDOWS WILL HAVE LIMITED MOVEMENT CONTINGENT ON FINAL FAA CERTIFICATION.
 - 6) ANY SEAT FORWARD AND AFT OF A BULKHEAD WILL HAVE LIMITED MOVEMENT CONTINGENT ON FINAL FAA CERTIFICATION.
 - 7) CABIN FEATURES TO INCLUDE 3-ZONE ENTERTAINMENT AUDIO SYSTEM.



2014 Gulfstream G650

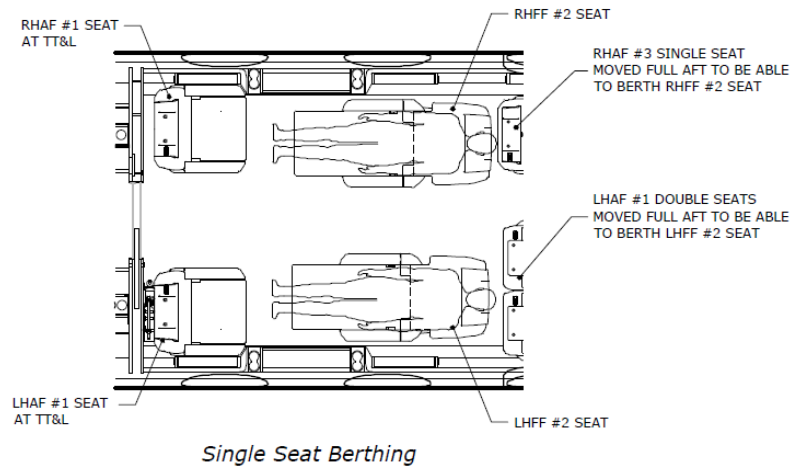

- 1) ALL DIMENSIONS SHOWN ARE APPROXIMATE.
- 2) CABIN BULKHEADS WITH AND WITHOUT POCKET DOORS AND SLIDING ACOUSTIC DOOR AT MAIN ENTRYWAY CONTINGENT UPON FINAL FAA CERTIFICATION.
- 3) POWERED SINGLE SEATS LOCATED AT No.2 RH AND No.2 LH POSITIONS.
- 4) PASSENGER OCCUPANCY FOR TAXI, TAKE-OFF AND LANDING IN THE FORWARD MOST SEAT OF THE DIVAN IS SUBJECT TO FAA APPROVAL.
- 5) ANY SEAT IN FRONT OF EMERGENCY WINDOWS WILL HAVE LIMITED MOVEMENT CONTINGENT ON FINAL FAA CERTIFICATION.
- 6) ANY SEAT FORWARD AND AFT OF A BULKHEAD WILL HAVE LIMITED MOVEMENT CONTINGENT ON FINAL FAA CERTIFICATION.
- 7) CABIN FEATURES TO INCLUDE 3-ZONE ENTERTAINMENT AUDIO SYSTEM.

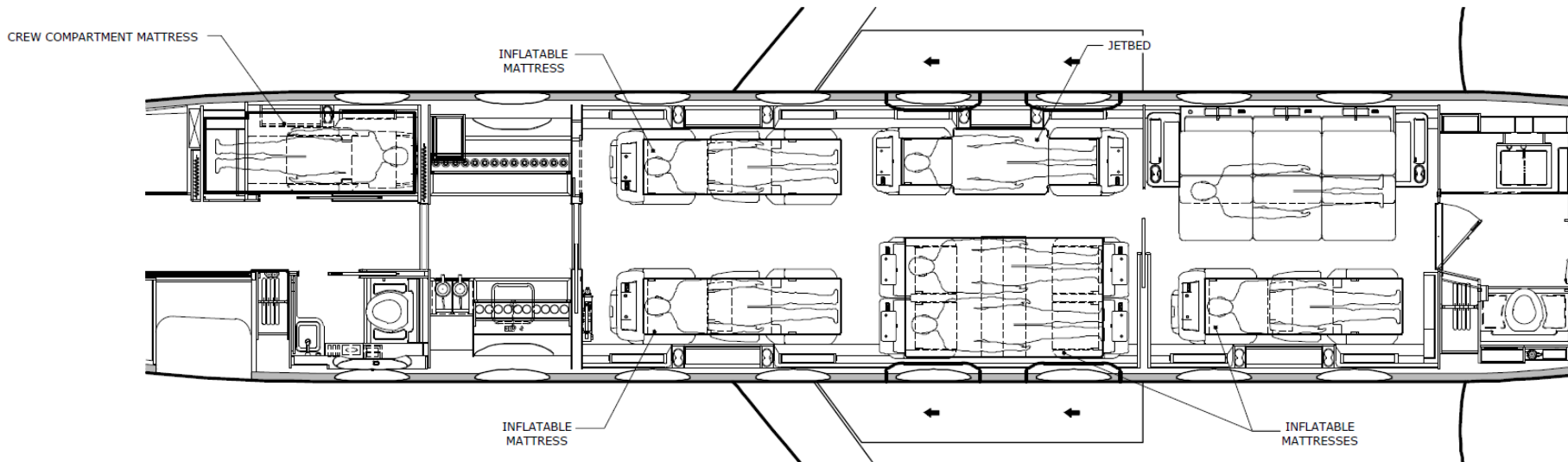

2014 Gulfstream G650 6085

Gulfstream G650

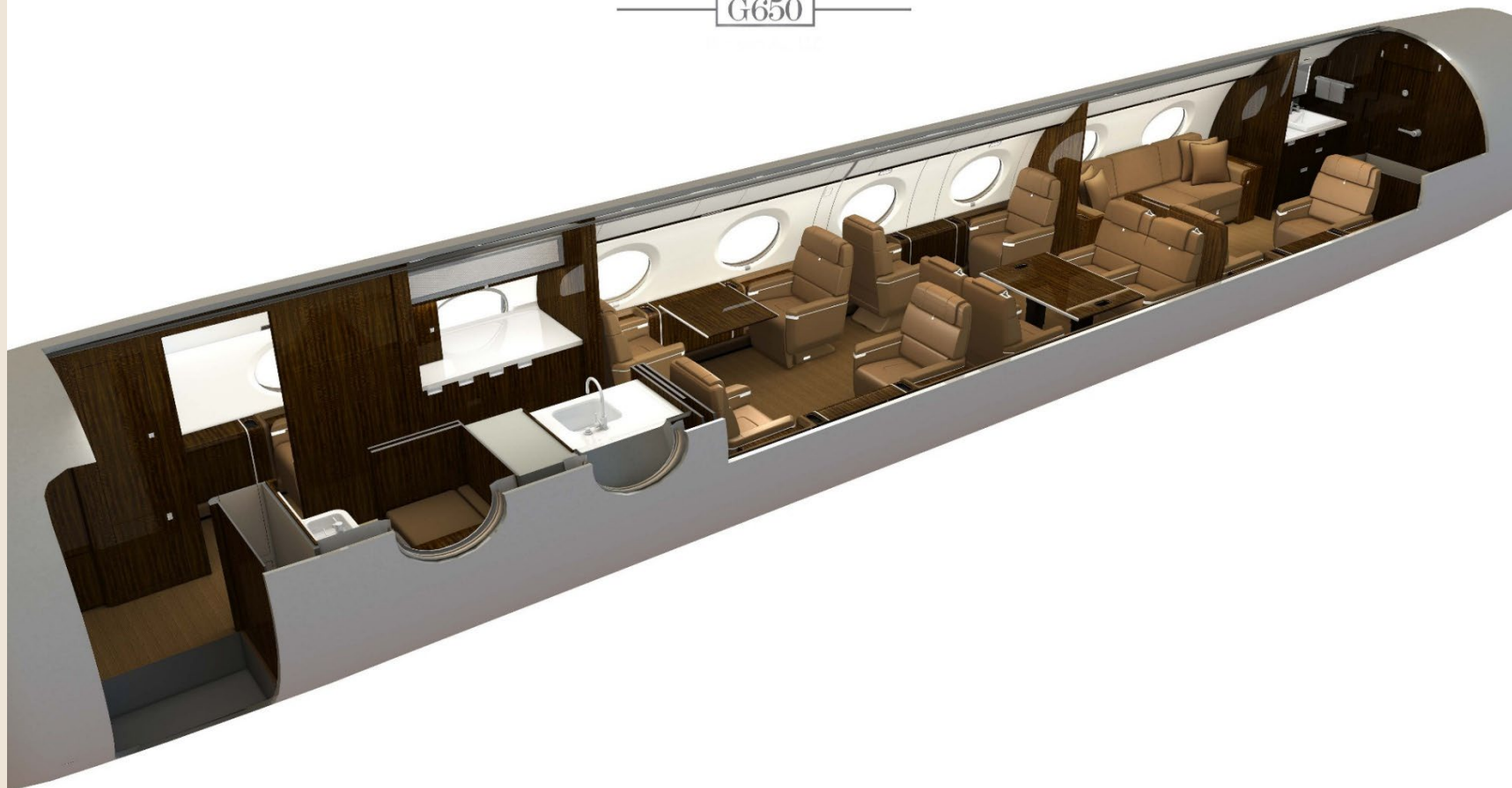

The data and information herein is sensitive data between the Customer and Gulfstream Aerospace Corporation. This data shall not be reproduced, used or disclosed to others without authorization of the Customer and Gulfstream Aerospace Corporation.

The renderings are intended to show conceptual design only. Configuration, colors, and patterns may vary from final aircraft. Please refer to the Design Package for the correct configuration and actual material representation.



FREESTREAM.COM
sales@freestream.com

29 Bruton Place London W1J 6NJ, UK
+44 20.7584.3800

Alireza Ittihadieh

2014 Gulfstream G650



FREESTREAM.COM
sales@freestream.com

29 Bruton Place London W1J 6NJ, UK
+44 20.7584.3800

Alireza Ittihadieh

2014 Gulfstream G650



FREESTREAM.COM
sales@freestream.com

29 Bruton Place London W1J 6NJ, UK
+44 20.7584.3800

Alireza Ittihadieh

Freestream Aircraft Limited is proud to have a team of highly experienced and uniquely qualified aviation consultants. Our team is able to cover all aspects of aircraft brokerage, acquisition, marketing, sales, custom design services, import/export and maintenance review of your aircraft. We specialize in state of the art, medium through ultra-long range corporate jet aircraft and fully understand the importance of attending to all details as required by our clients.

Additionally, our affiliation with brokerage firms worldwide and our collateral buying power with the aircraft manufacturers, assures professional assistance to international and multinational companies as well as private individuals, artists, royalty and head-of-state clients.

Freestream's expertise, commitment to integrity, and vast experience provide our clientele the exclusive opportunity to experience a seamless transaction in a timely manner. Principals the world over continue to find their experience with Freestream advantageous and beneficial.

Freestream Aircraft Limited

29 Bruton Place London W1J 6NJ, UK

+44 20.7584.3800

www.freestream.com



FREESTREAM.COM
sales@freestream.com

29 Bruton Place London W1J 6NJ, UK
+44 20.7584.3800

Alireza Ittihadieh